

Unit 7, Castle Industrial Centre, Queensferry road, Dunfermline, Fife, KY11 8PX, SCOTLAND
 Tel 44(0)1383 626659 Fax: 44(0)1383 626828 mail@submertec.co.uk

150 Watt Metal Halide Underwater Floodlight

GUARDIAN Model UFL-150MH



Initially manufactured for use on submersibles, these very efficient lights provide extremely bright, even illumination over a wide area and are ideal for a wide range of applications.

An Aluminium Bronze version is available for long term, corrosion free installation into Marine Aquaria, docks etc.

Lights can be supplied with bulkhead underwater connectors fitted or cables moulded directly to a right angle penetrator.

Use of Wet Mateable connectors ensures that the cable can be disconnected and reconnected underwater to allow the light can be recovered to the surface for re-lamping when required.

Underwater cables up to 20 Metres long can be supplied for connection to the surface mounted ballast unit.

The lights can be supplied with traditional wound ballasts or with the latest Electronic Ballasts for operation from a variety of power sources including 120 Volts DC, 120 Volts AC and 240 Volts AC.

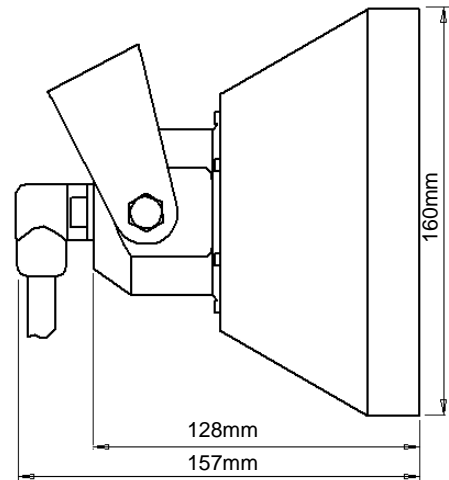
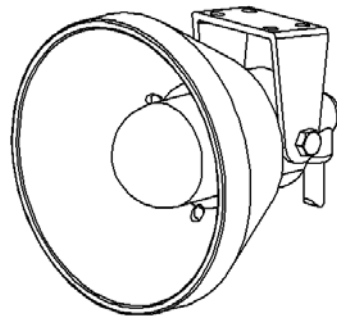

UNDERWATER FLOODLIGHT SPECIFICATION	
Diameter	160 mm
Overall length	157mm incl connector, 128mm excl connector
Weight	1.6Kg (3.5lb)
Depth Rating	310 Metre (1017 feet)
Material	Stainless Steel or Aluminium Bronze
Beam Angle	138 degrees
Lamp type	Osram or Radium HQI T 150
Ballast type	External ballast required

A range of Guardian underwater lights are available to suit different applications—please visit our web site at www.submertec.co.uk to view these together with other Submertec products.